

CAPACITY	SYMBOL/ CODE NO.	CIRCUIT DIAGRAM
AC100~240V, 50/60Hz		
6Wx2		

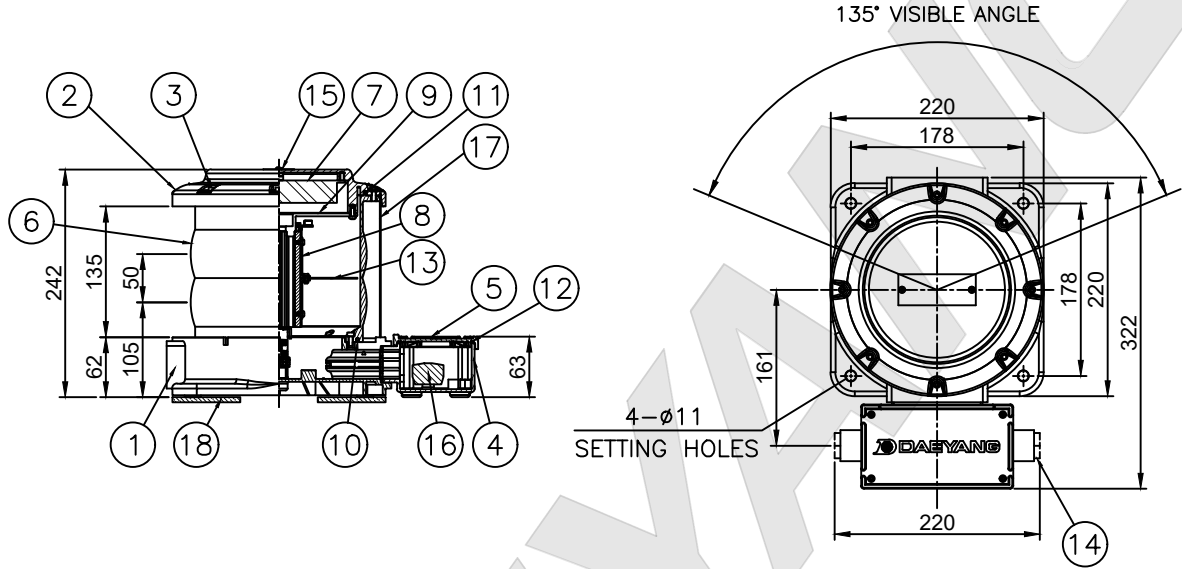

NOTE

- APPLICATION RANGE : VESSEL OF 50M IN LENGTH AND ABOVE
- MINIMUM VISIBILITY : 3 N.M

CAUTION!!

- * Do not install the navigation light upside down.
(설치 시 주의 하십시오. 항해등을 거꾸로 설치하지 마십시오.)
- * If luminous intensity is decreased by 30%, LED fail is considered to be the power off.
(광도의 30%가 감소하게 되면 LED fail로 간주하여 전원을 차단합니다.)
- * Be careful not to touch or contaminate LED chip, PCB, driver.
If there is the damage due to contamination, we can not guarantee the product.
(LED chip, PCB, driver를 만지거나 오염되지 않도록 주의하세요.)
(오염으로 인한 손상 발생 시, 제품을 보증 할 수 없습니다.)

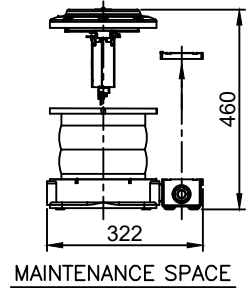

18	ANTI-VIBRATION PACKING	EPDM	4	5mm	9	DRIVER COVER	-	1	
17	SHIELD PLATE	STAINLESS STEEL 316L	1		8	LED module	-	2	WHITE
16	TERMINAL BLOCK	-	1	CLAMPING 5P (2.5sq)	7	LED driver	-	2	
15	NAME PLATE	STAINLESS STEEL 316	1		6	LENS	POLYCAR-BONATE	1	CLEAR
14	CABLE GLAND	BRASS	2	M24xW16 (ø14~16)	5	JUNCTION BOX COVER	POLYCAR-BONATE	1	
13	CENTER SHIELD PLATE	STAINLESS STEEL 304	1		4	JUNCTION BOX	POLYCAR-BONATE	1	
12	JUNCTION BOX PACKING	SILICONE	1		3	COVER BOLT	STAINLESS STEEL 316	8	
11	COVER GASKET	SILICONE	1		2	COVER	POLYCAR-BONATE	1	
10	BODY GASKET	SILICONE	1		1	BODY	POLYCAR-BONATE	1	
NO	NAME OF PARTS	MATERIAL	Q'TY	REMARKS	NO	NAME OF PARTS	MATERIAL	Q'TY	REMARKS

APPROVED	J. W. PARK	UNIT	MM	TITLE; LED STERN LIGHT FOR MARINE USE				
CHECKED	O. J. KWON	SCALE	N/S					
DRAWING	J. C. LEE	COLOR	MAT BLACK					
DATE	2020.12.24	IP	66/67					
					MODEL NO.	A2J-DS0655-MED	WEIGHT	5 kg
					DRAWING NO.	LQ1240064	SHEET NO.	8